

TL1018 SERIES TACT SWITCH

APPLICATIONS / MARKETS

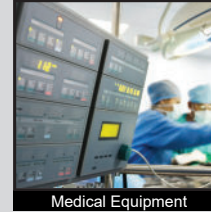
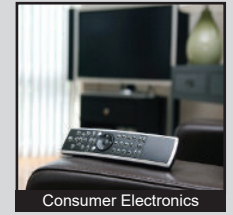
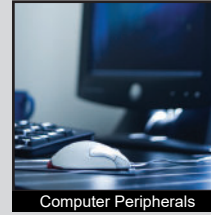
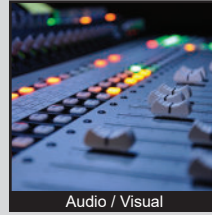
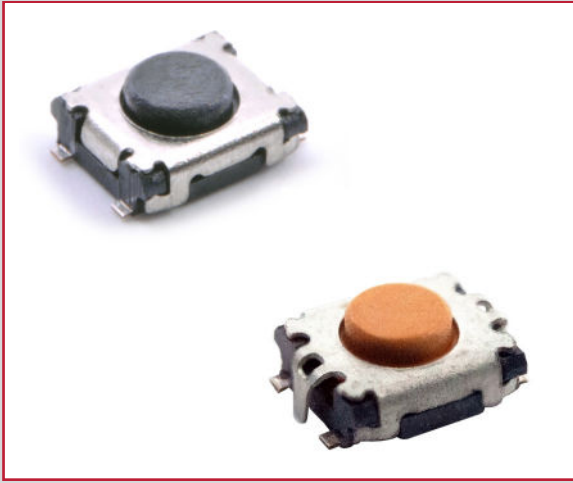

RoHS

SPECIFICATIONS

Electrical Rating: 50mA, 12VDC
Contact Resistance: 100mΩ Max. (Initial)
Insulation Resistance: 100MΩ Min. at 500VDC
Dielectric Strength: 250VAC for 1 Minute
Life Cycles: 500,000 cycles for 160gf
 200,000 cycles for 240gf, 340gf, and 450gf
Operating Temperature: -40°C to 85°C
Storage Temperature: -40°C to 85°C
Travel: 0.15mm ±0.1mm
Operating Force: F160 - 160 ±50gf, F240 - 240 ±70gf,
 F340 - 340 ±70gf, and F450 - 450 ±80gf
Function: SPST, Off-(On)
Packaging: Tape and Reel, 9,500 pcs/reel

FEATURES & BENEFITS

- Surface mount design
- 3.5 x 2.6 mm size
- Up to 500,000 cycle life expectancy
- Multiple actuation force options
- Ground terminal option
- Tape and Reel packaging

PART NUMBER CONFIGURATOR

Series	Actuator Height	Bosses	Ground Terminal	Actuation Force	Contact Plating	Termination
<input type="text" value="TL1018"/>	<input type="text" value="A - 1.4mm"/>	<input type="text" value="A - Without Bosses"/>	<input type="text" value="A - Without Ground Terminal"/>	<input type="text" value="F160 - 160 ±50gf"/>	<input type="text" value="Q - Silver"/>	<input type="text" value="G - Gull-wing"/>
			<input type="text" value="B - With Ground Terminal"/>	<input type="text" value="F240 - 240 ±70gf"/>		
				<input type="text" value="F340 - 340 ±70gf"/>		
				<input type="text" value="F450 - 450 ±80gf"/>		

Specifications subject to change without notice 4.2.2024



E-SWITCH®

www.e-switch.com

800.867.2717

1

ANTI-VANDAL SWITCHES
 DETECTOR SWITCHES
 DIP SWITCHES
 KEYLOCK SWITCHES
 NAVIGATION SWITCHES
 PUSHBUTTON SWITCHES
 ROCKER SWITCHES
 ROTARY SWITCHES
 SLIDE SWITCHES
 SNAP ACTION SWITCHES
TACTILE SWITCHES
 TOGGLE SWITCHES
 CAP OPTIONS

TL1018 SERIES TACT SWITCH

BODY DIMENSIONS WITHOUT BOSSES AND GROUND TERMINAL

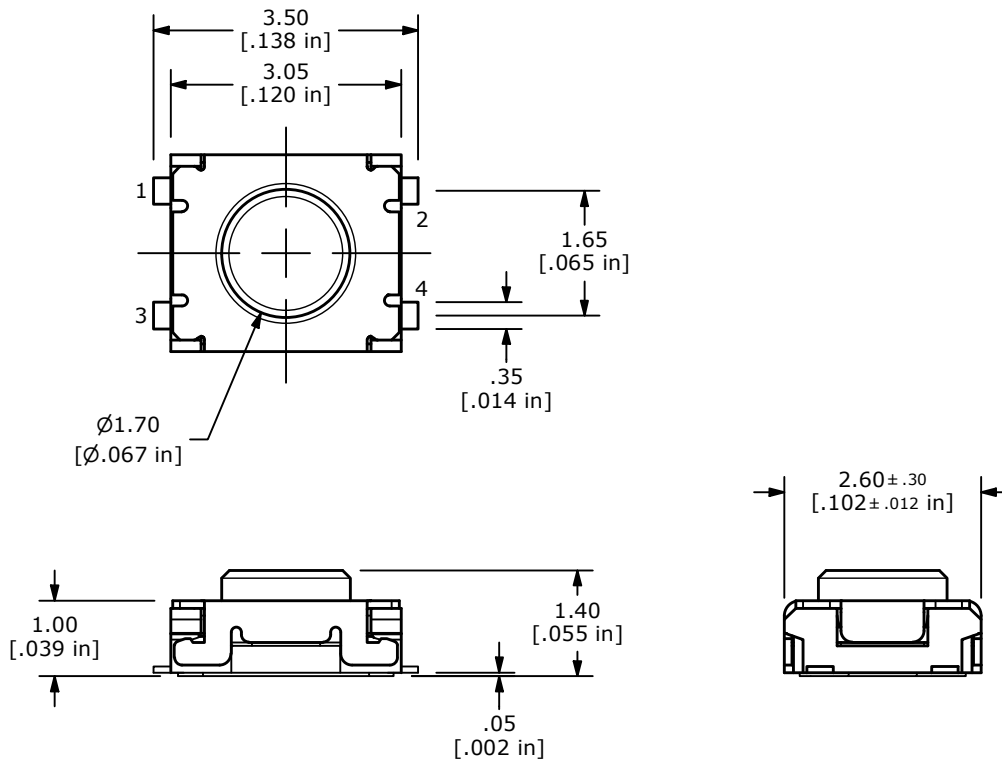
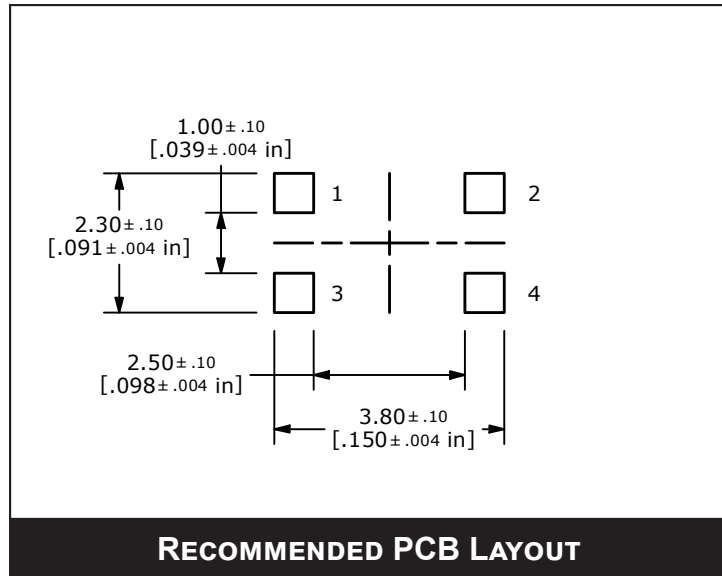
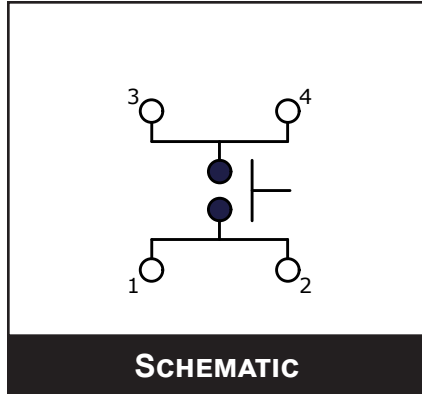

TL1018 SERIES TACT SWITCH

BODY DIMENSIONS WITHOUT BOSSES AND WITH GROUND TERMINAL

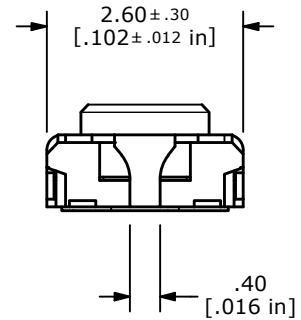
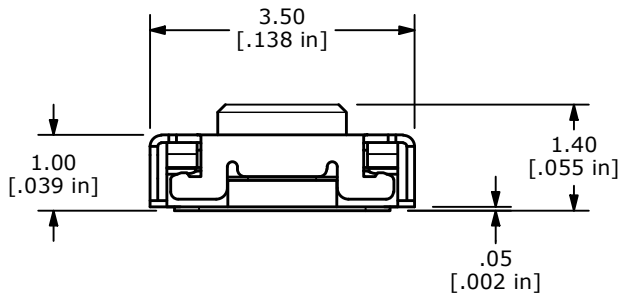
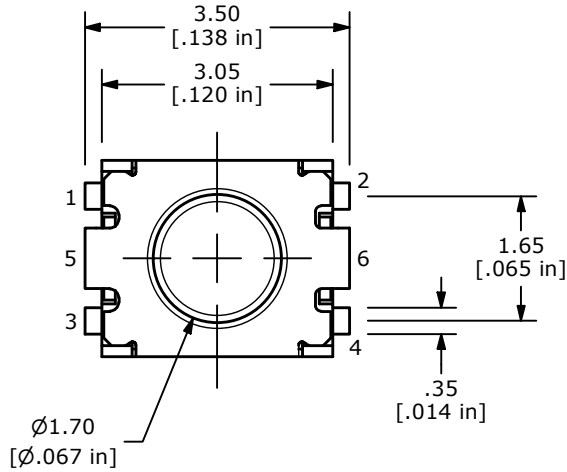
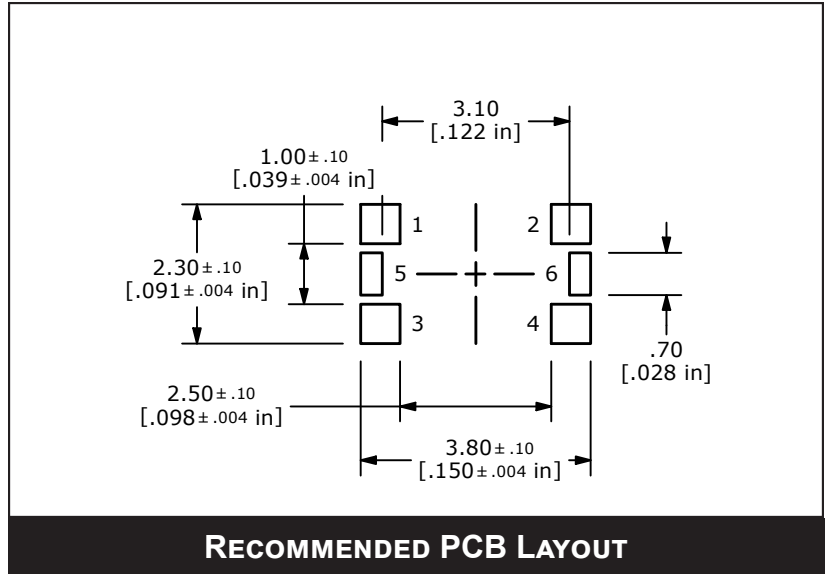
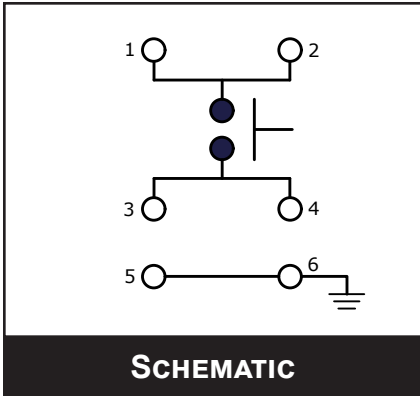

TL1018 SERIES TACT SWITCH

BODY DIMENSIONS TAPE AND REEL

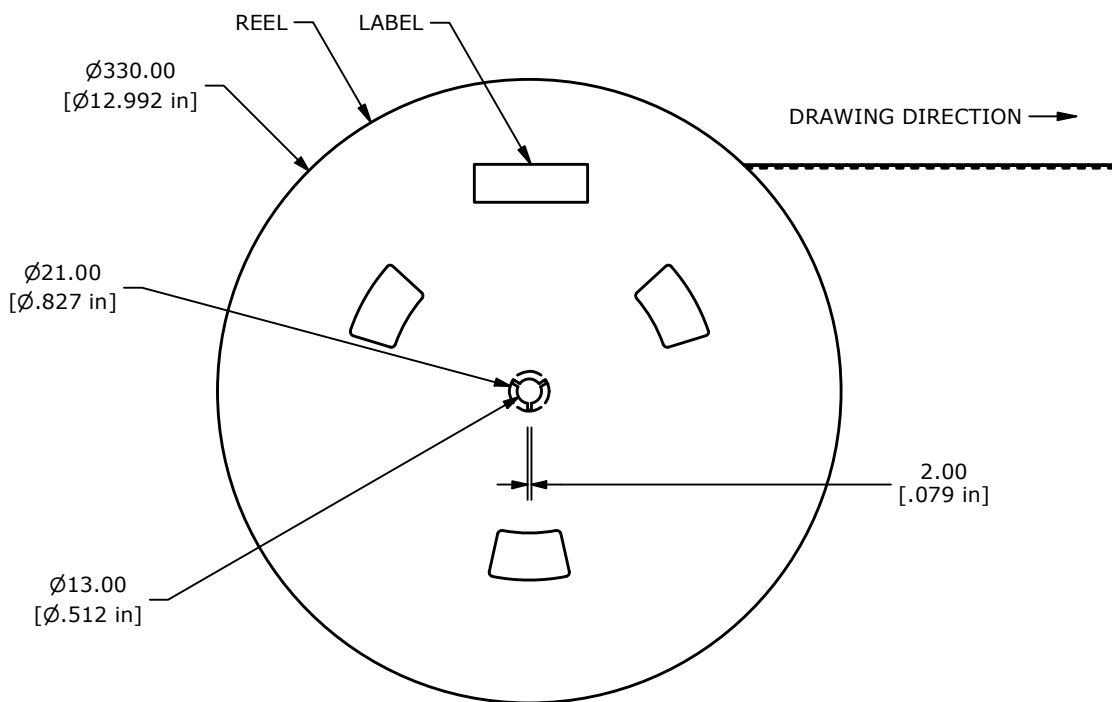
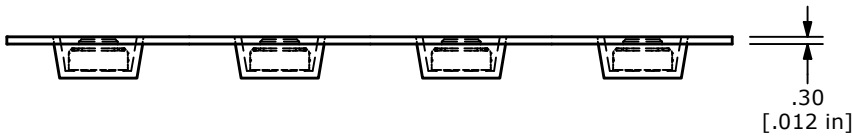
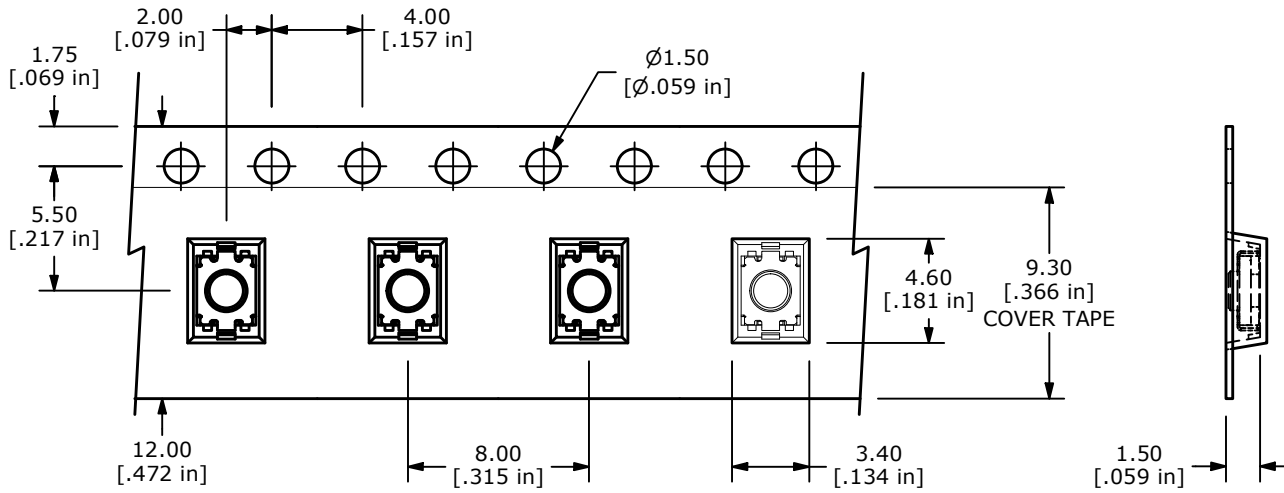

- ANTI-VANDAL SWITCHES
- DETECTOR SWITCHES
- DIP SWITCHES
- KEYLOCK SWITCHES
- NAVIGATION SWITCHES
- PUSHBUTTON SWITCHES
- ROCKER SWITCHES
- ROTARY SWITCHES
- SLIDE SWITCHES
- SNAP ACTION SWITCHES
- TACTILE SWITCHES
- TOGGLE SWITCHES
- CAP OPTIONS

TL1018 SERIES TACT SWITCH

RECOMMENDED SOLDER PROCESS

Most contamination problems can be prevented by exercising care during the cleaning and soldering process. Care should be taken not to immerse or spray unsealed switches during flux removal. Contact E-Switch for specific soldering recommendations and specifications not shown. Generalized soldering procedures are outlined below.

“TYPICAL” SMT REFLOW (Pb and Pb-Free)

Profile Feature	Sn-Pb Eutectic Assembly	Pb-Free Assembly
Average Ramp-Up Rate ($T_{s_{max}}$ to T_p)	3 °C/second max.	3 °C/second max.
Preheat		
-Temperature Min ($T_{s_{min}}$)	100 °C	150 °C
-Temperature Max ($T_{s_{max}}$)	150 °C	200 °C
-Time ($t_{s_{min}}$ to $t_{s_{max}}$)	60-120 seconds	60-180 seconds
Time Maintained above:		
-Temperature (T_L)	183 °C	217 °C
-Time (t_L)	60-150 seconds	60-150 seconds
Time within 5 °C of actual Peak Temperature (t_p)	10-30 seconds	20-40 seconds
Ramp-Down Rate	6 °C/second max.	6 °C/second max.
Time 25 °C to Peak Temperature	6 minutes max.	8 minutes max.

Note 1: All temperatures refer to topside of the package, measured on the package surface.

