

# SERIES TL 3200 SWITCHES

TACT SWITCHES SMT, LED - 4.5mm x 6.8mm

TACT SWITCHES

NAVIGATION SWITCHES

PUSHBUTTON SWITCHES

TOGGLE SWITCHES

ROCKER SWITCHES

SLIDE SWITCHES

SNAP-ACTION SWITCHES

DIP SWITCHES

KEYLOCK SWITCHES

ROTARY SWITCHES

DETECTOR SWITCHES

CAP OPTIONS



## SPECIFICATIONS

Contact Rating:	50mA @ 12 VDC
Life Expectancy:	30,000 cycles
Contact Resistance:	500mΩ
Insulation Resistance:	100MΩ min.
Dielectric Strength:	250 VAC
Actuation Force:	160 +75/-30 grams
Operating Temperature:	-25°C to 85°C
Travel:	0.25mm +0.2/-0.1mm

## FEATURES & BENEFITS

- ▶ Dual LED, SMT Design
- ▶ Ultra miniature design (only 4.5mm x 6.8mm x 2mm)
- ▶ Single or dual color option

## APPLICATIONS/MARKETS

- ▶ Telecommunications
- ▶ Consumer Electronics
- ▶ Audio/visual
- ▶ Medical
- ▶ Testing/instrumentation
- ▶ Computer/servers/peripherals

## MATERIALS

Cover:	Nylon
Actuator:	LCP
Base:	LCP
Terminals:	Copper alloy, silver plated

## HOW TO ORDER

SERIES	MODEL NO.	ACTUATOR ("L" Dimension)	OPERATING FORCE	LED #1	LED #2	CONTACT MATERIAL
TL	3200	A = 2.5mm	F160	R = Red G = Green Y = Yellow B = Blue W = White N = None	R = Red G = Green Y = Yellow B = Blue W = White N = None	Q = Silver

▶ ▶ ▶ Example Ordering Number  
TL-3200-A-F160-R-N-Q

Specifications subject to change without notice.

## TL 3200

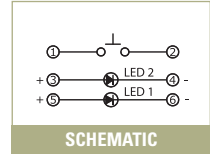
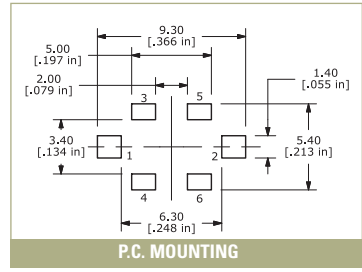
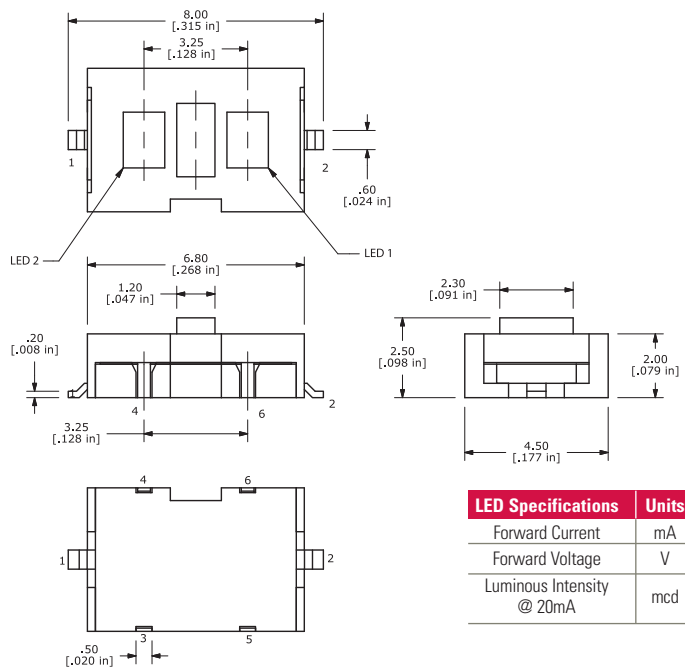

LED Specifications	Units	Green	Red	Yellow	Blue	White
Forward Current	mA	30	15	20	15	30
Forward Voltage	V	1.7-2.6	1.7-2.6	1.7-2.6	3.5-3.8	3.5-4.0
Luminous Intensity @ 20mA	mcd	6	4	5	45	180